

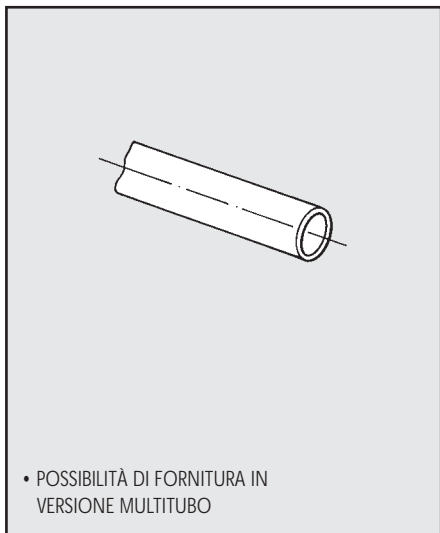

# TUBI

| TUBO IN POLIAMMIDE | Cod. PA11      | Cod. PA12      | Colore  | Diam. mm |      | Peso<br>kg./100 mt. | Raggio di<br>curvatura mm. | P eser. a 20°C<br>(bar) |
|--------------------|----------------|----------------|---------|----------|------|---------------------|----------------------------|-------------------------|
|                    |                |                |         | est.     | int. |                     |                            |                         |
|                    | Z00W0980110001 | Z00W0980120001 | Neutro  | 4        | 2    | 1                   | 20                         | 56                      |
|                    | Z00W0980110002 | Z00W0980120002 | Rosso   |          |      |                     |                            |                         |
|                    | Z00W0980110003 |                | Giallo  |          |      |                     |                            |                         |
|                    | Z00W0980110004 | Z00W0980120004 | Blu     |          |      |                     |                            |                         |
|                    | Z00W0980110005 |                | Verde   |          |      |                     |                            |                         |
|                    | Z00W0980110006 | Z00W0980120006 | Nero    |          |      |                     |                            |                         |
|                    | Z00W0980110007 | Z00W0980120007 | Azzurro |          |      |                     |                            |                         |
|                    | Z00W0980110101 | Z00W0980120101 | Neutro  | 4        | 2,5  | 0,788               | 20                         | 38                      |
|                    | Z00W0980110102 | Z00W0980120102 | Rosso   |          |      |                     |                            |                         |
|                    | Z00W0980110103 |                | Giallo  |          |      |                     |                            |                         |
|                    | Z00W0980110104 | Z00W0980120104 | Blu     |          |      |                     |                            |                         |
|                    | Z00W0980110105 | Z00W0980120105 | Verde   |          |      |                     |                            |                         |
|                    | Z00W0980110106 | Z00W0980120106 | Nero    |          |      |                     |                            |                         |
|                    | Z00W0980110107 | Z00W0980120107 | Azzurro |          |      |                     |                            |                         |
|                    | Z00W0980110011 | Z00W0980120011 | Neutro  | 4        | 2,7  | 0,720               | 25                         | 32                      |
|                    | Z00W0980110012 | Z00W0980120012 | Rosso   |          |      |                     |                            |                         |
|                    | Z00W0980110013 | Z00W0980120013 | Giallo  |          |      |                     |                            |                         |
|                    | Z00W0980110014 | Z00W0980120014 | Blu     |          |      |                     |                            |                         |
|                    | Z00W0980110015 | Z00W0980120015 | Verde   |          |      |                     |                            |                         |
|                    | Z00W0980110016 | Z00W0980120016 | Nero    |          |      |                     |                            |                         |
|                    | Z00W0980110017 | Z00W0980120017 | Azzurro |          |      |                     |                            |                         |
|                    | Z00W0980110021 | Z00W0980120021 | Neutro  | 5        | 3    | 1,350               | 25                         | 33                      |
|                    | Z00W0980110022 |                | Rosso   |          |      |                     |                            |                         |
|                    | Z00W0980110023 |                | Giallo  |          |      |                     |                            |                         |
|                    | Z00W0980110024 |                | Blu     |          |      |                     |                            |                         |
|                    | Z00W0980110025 |                | Verde   |          |      |                     |                            |                         |
|                    | Z00W0980110026 | Z00W0980120026 | Nero    |          |      |                     |                            |                         |
|                    | Z00W0980110027 |                | Azzurro |          |      |                     |                            |                         |
|                    | Z00W0980110031 | Z00W0980120031 | Neutro  | 6        | 4    | 1,650               | 35                         | 33                      |
|                    | Z00W0980110032 | Z00W0980120032 | Rosso   |          |      |                     |                            |                         |
|                    | Z00W0980110033 | Z00W0980120033 | Giallo  |          |      |                     |                            |                         |
|                    | Z00W0980110034 | Z00W0980120034 | Blu     |          |      |                     |                            |                         |
|                    | Z00W0980110035 | Z00W0980120035 | Verde   |          |      |                     |                            |                         |
|                    | Z00W0980110036 | Z00W0980120036 | Nero    |          |      |                     |                            |                         |
|                    | Z00W0980110037 | Z00W0980120037 | Azzurro |          |      |                     |                            |                         |
|                    | Z00W0980110041 | Z00W0980120041 | Neutro  | 8        | 6    | 2,340               | 40                         | 24                      |
|                    | Z00W0980110042 | Z00W0980120042 | Rosso   |          |      |                     |                            |                         |
|                    | Z00W0980110043 | Z00W0980120043 | Giallo  |          |      |                     |                            |                         |
|                    | Z00W0980110044 | Z00W0980120044 | Blu     |          |      |                     |                            |                         |
|                    | Z00W0980110045 | Z00W0980120045 | Verde   |          |      |                     |                            |                         |
|                    | Z00W0980110046 | Z00W0980120046 | Nero    |          |      |                     |                            |                         |
|                    | Z00W0980110047 | Z00W0980120047 | Azzurro |          |      |                     |                            |                         |
|                    | Z00W0980110051 | Z00W0980120051 | Neutro  | 10       | 8    | 2,980               | 60                         | 19                      |
|                    | Z00W0980110052 | Z00W0980120052 | Rosso   |          |      |                     |                            |                         |
|                    | Z00W0980110053 |                | Giallo  |          |      |                     |                            |                         |
|                    | Z00W0980110054 | Z00W0980120054 | Blu     |          |      |                     |                            |                         |
|                    | Z00W0980110055 | Z00W0980120055 | Verde   |          |      |                     |                            |                         |
|                    | Z00W0980110056 | Z00W0980120056 | Nero    |          |      |                     |                            |                         |
|                    | Z00W0980110057 | Z00W0980120057 | Azzurro |          |      |                     |                            |                         |

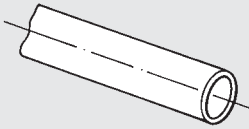

| TUBO IN POLIAMMIDE  | Cod. PA11      | Cod. PA12      | Colore  | Diam. mm |      | Peso<br>kg./100 mt. | Raggio di<br>curvatura mm. | P eser. a 20°C<br>(bar) |
|---|----------------|----------------|---------|----------|------|---------------------|----------------------------|-------------------------|
|   |                |                |         | est.     | int. |                     |                            |                         |
|  <p>• POSSIBILITÀ DI FORNITURA IN VERSIONE MULTITUBO</p> | Z00W0980110061 | Z00W0980120061 | Neutro  | 12       | 10   | 3,660               | 85                         | 17                      |
|   | Z00W0980110062 | Z00W0980120062 | Rosso   |          |      |                     |                            |                         |
|   | Z00W0980110063 |                | Giallo  |          |      |                     |                            |                         |
|   | Z00W0980110064 | Z00W0980120064 | Blu     |          |      |                     |                            |                         |
|   | Z00W0980110065 |                | Verde   |          |      |                     |                            |                         |
|   | Z00W0980110066 | Z00W0980120066 | Nero    |          |      |                     |                            |                         |
|   | Z00W0980110067 | Z00W0980120067 | Azzurro |          |      |                     |                            |                         |
|   | Z00W0980110071 | Z00W0980120071 | Neutro  | 14       | 12   | 4,300               | 90                         | 15                      |
|   | Z00W0980110072 |                | Rosso   |          |      |                     |                            |                         |
|   | Z00W0980110073 |                | Giallo  |          |      |                     |                            |                         |
|   | Z00W0980110074 |                | Blu     |          |      |                     |                            |                         |
|   | Z00W0980110075 |                | Verde   |          |      |                     |                            |                         |
|   | Z00W0980110076 | Z00W0980120076 | Nero    |          |      |                     |                            |                         |
|   | Z00W0980110077 |                | Azzurro |          |      |                     |                            |                         |
|   | Z00W0980110081 | Z00W0980120081 | Neutro  | 15       | 12   | 6,700               | 90                         | 20                      |
|   | Z00W0980110082 |                | Rosso   |          |      |                     |                            |                         |
|   | Z00W0980110084 |                | Blu     |          |      |                     |                            |                         |
|   | Z00W0980110086 | Z00W0980120086 | Nero    |          |      |                     |                            |                         |
|   | Z00W0980110087 |                | Azzurro |          |      |                     |                            |                         |
|   | Z00W0980110091 | Z00W0980120091 | Neutro  | 15       | 12,5 | 5,725               | 100                        | 16                      |
|   | Z00W0980110094 | Z00W0980120094 | Blu     |          |      |                     |                            |                         |
|   | Z00W0980110096 |                | Nero    |          |      |                     |                            |                         |
|   | Z00W0980110097 |                | Azzurro |          |      |                     |                            |                         |

| TUBO-SPIRALE PA11   | Cod.           | Colore  | Diam. mm Ø |      |              | Tubo lineare<br>mt. | A riposo<br>mt. | Utilizzo<br>max/mt. |
|---|----------------|---------|------------|------|--------------|---------------------|-----------------|---------------------|
|   |                |         | est.       | int. | int. spirale |                     |                 |                     |
|  <p>• POSSIBILITÀ DI FORNITURA IN VERSIONE MULTITUBO</p> | Z00W0980210001 | Neutro  | 4          | 2,5  | 20           | 10                  | 0,460           | 6,50                |
|   | Z00W0980210002 | Blu     |            |      |              |                     |                 |                     |
|   | Z00W0980210003 | Arancio |            |      |              |                     |                 |                     |
|   | Z00W0980210011 | Neutro  | 6          | 4    | 55           | 30                  | 0,950           | 20                  |
|   | Z00W0980210012 | Blu     |            |      |              |                     |                 |                     |
|   | Z00W0980210013 | Arancio |            |      |              |                     |                 |                     |
|   | Z00W0980210021 | Neutro  | 8          | 6    | 70           | 30                  | 1,000           | 20                  |
|   | Z00W0980210022 | Blu     |            |      |              |                     |                 |                     |
|   | Z00W0980210023 | Arancio |            |      |              |                     |                 |                     |
|   | Z00W0980210031 | Neutro  | 10         | 8    | 90           | 30                  | 1,000           | 20                  |
|   | Z00W0980210032 | Blu     |            |      |              |                     |                 |                     |
|   | Z00W0980210033 | Arancio |            |      |              |                     |                 |                     |
|   | Z00W0980210041 | Neutro  | 12         | 10   | 110          | 30                  | 1,000           | 20                  |
|   | Z00W0980210042 | Blu     |            |      |              |                     |                 |                     |
| Z00W0980210043  | Arancio        |         |            |      |              |                     |                 |                     |

| TUBO-SPIRALE PA11<br>CON TERMINALE  | Cod.           | Colore  | Diam. mm Ø |      |              | Tubo lineare<br>mt. | A riposo<br>mt. | Utilizzo<br>max/mt. |
|---|----------------|---------|------------|------|--------------|---------------------|-----------------|---------------------|
|   |                |         | est.       | int. | int. spirale |                     |                 |                     |
|  <p>• POSSIBILITÀ DI FORNITURA IN VERSIONE MULTITUBO</p> | Z00W0980210101 | Neutro  | 4          | 2,5  | 30           | 2,5                 | 0,90            | 1,5                 |
|   | Z00W0980210103 | Arancio |            |      |              |                     |                 |                     |
|   | Z00W0980210111 | Neutro  | 6          | 4    | 50           | 10                  | 0,340           | 6,5                 |
|   | Z00W0980210112 | Blu     |            |      |              |                     |                 |                     |
|   | Z00W0980210113 | Arancio |            |      |              |                     |                 |                     |
|   | Z00W0980210121 | Neutro  | 8          | 6    | 60           | 10                  | 0,390           | 6,5                 |
|   | Z00W0980210122 | Blu     |            |      |              |                     |                 |                     |
|   | Z00W0980210123 | Arancio |            |      |              |                     |                 |                     |
|   | Z00W0980210131 | Neutro  | 10         | 8    | 80           | 10                  | 0,380           | 6,5                 |
|   | Z00W0980210132 | Blu     |            |      |              |                     |                 |                     |
|   | Z00W0980210133 | Arancio |            |      |              |                     |                 |                     |
|   | Z00W0980210141 | Neutro  | 12         | 10   | 100          | 10                  | 0,350           | 6,5                 |
|   | Z00W0980210142 | Blu     |            |      |              |                     |                 |                     |
|   | Z00W0980210143 | Arancio |            |      |              |                     |                 |                     |

**TUBO PTU 98**

• POSSIBILITÀ DI FORNITURA IN  
VERSIONE MULTITUBO

| Cod.           | Colore          | Diam. mm |      | Peso<br>kg./100 mt. | Raggio di<br>curvatura mm. | P eser. a 20°C<br>(bar) |
|----------------|-----------------|----------|------|---------------------|----------------------------|-------------------------|
|                |                 | est.     | int. |                     |                            |                         |
| Z00W0980410001 | Neutro          | 4        | 2    | 1,150               | 20                         | 22                      |
| Z00W0980410002 | Azzurro         |          |      |                     |                            |                         |
| Z00W0980410003 | Nero            |          |      |                     |                            |                         |
| Z00W0980410004 | Azz. traslucido |          |      |                     |                            |                         |
| Z00W0980410005 | Silver          |          |      |                     |                            |                         |
| Z00W0980410051 | Neutro          | 4        | 2,5  | 0,949               | 20                         | 15                      |
| Z00W0980410052 | Azzurro         |          |      |                     |                            |                         |
| Z00W0980410053 | Nero            |          |      |                     |                            |                         |
| Z00W0980410054 | Azz. traslucido |          |      |                     |                            |                         |
| Z00W0980410055 | Silver          |          |      |                     |                            |                         |
| Z00W0980410011 | Neutro          | 5        | 3    | 1,600               | 25                         | 17                      |
| Z00W0980410012 | Azzurro         |          |      |                     |                            |                         |
| Z00W0980410013 | Nero            |          |      |                     |                            |                         |
| Z00W0980410014 | Azz. traslucido |          |      |                     |                            |                         |
| Z00W0980410021 | Neutro          | 6        | 4    | 2,050               | 30                         | 13                      |
| Z00W0980410022 | Azzurro         |          |      |                     |                            |                         |
| Z00W0980410023 | Nero            |          |      |                     |                            |                         |
| Z00W0980410024 | Azz. traslucido |          |      |                     |                            |                         |
| Z00W0980410025 | Silver          |          |      |                     |                            |                         |
| Z00W0980410062 | Azzurro         | 8        | 5    | 3,796               | 40                         | 15                      |
| Z00W0980410064 | Azz. traslucido |          |      |                     |                            |                         |
| Z00W0980410065 | Silver          |          |      |                     |                            |                         |
| Z00W0980410031 | Neutro          | 8        | 6    | 2,800               | 40                         | 10                      |
| Z00W0980410032 | Azzurro         |          |      |                     |                            |                         |
| Z00W0980410033 | Nero            |          |      |                     |                            |                         |
| Z00W0980410034 | Azz. traslucido |          |      |                     |                            |                         |
| Z00W0980410035 | Silver          |          |      |                     |                            |                         |
| Z00W0980410072 | Azzurro         | 10       | 7,5  | 4,259               | 40                         | 10                      |
| Z00W0980410074 | Azz. traslucido |          |      |                     |                            |                         |
| Z00W0980410041 | Neutro          | 10       | 8    | 3,900               | 50                         | 8                       |
| Z00W0980410042 | Azzurro         |          |      |                     |                            |                         |
| Z00W0980410043 | Nero            |          |      |                     |                            |                         |
| Z00W0980410044 | Azz. traslucido |          |      |                     |                            |                         |
| Z00W0980410082 | Azzurro         | 12       | 8    | 7,787               | 30                         | 13                      |
| Z00W0980410084 | Azz. traslucido |          |      |                     |                            |                         |
| Z00W0980410092 | Azzurro         | 12       | 9    | 6,182               | 50                         | 10                      |
| Z00W0980410094 | Azz. traslucido |          |      |                     |                            |                         |

**TUBO NYLON**

• POSSIBILITÀ DI FORNITURA IN  
VERSIONE MULTITUBO

| Cod.           | Colore  | Diam. mm |      | Peso<br>kg./100 mt. | Raggio di<br>curvatura mm. | P eser. a 20°C<br>(bar) |
|----------------|---------|----------|------|---------------------|----------------------------|-------------------------|
|                |         | est.     | int. |                     |                            |                         |
| Z00W0980710001 | Neutro  | 4        | 2    | 1,080               | 25                         | 80                      |
| Z00W0980710002 | Nero    |          |      |                     |                            |                         |
| Z00W0980710003 | Azzurro |          |      |                     |                            |                         |
| Z00W0980710031 | Neutro  | 6        | 4    | 1,790               | 45                         | 45                      |
| Z00W0980710032 | Nero    |          |      |                     |                            |                         |
| Z00W0980710033 | Azzurro |          |      |                     |                            |                         |
| Z00W0980710041 | Neutro  | 8        | 6    | 2,510               | 65                         | 35                      |
| Z00W0980710042 | Nero    |          |      |                     |                            |                         |
| Z00W0980710043 | Azzurro |          |      |                     |                            |                         |
| Z00W0980710051 | Neutro  | 10       | 8    | 3,220               | 80                         | 25                      |
| Z00W0980710052 | Nero    |          |      |                     |                            |                         |
| Z00W0980710053 | Azzurro |          |      |                     |                            |                         |
| Z00W0980710061 | Neutro  | 12       | 10   | 4,000               | 100                        | 23                      |
| Z00W0980710062 | Nero    |          |      |                     |                            |                         |
| Z00W0980710063 | Azzurro |          |      |                     |                            |                         |

**TUBO PVC AZZURRO RINFORZATO**

| Cod.           | Ø Int.<br>mm | Ø Est.<br>mm | Peso<br>g/m | Press. Es.<br>kg/cm <sup>2</sup> | Press. Scopp.<br>kg/cm <sup>2</sup> | LG rotolo<br>m | Volume<br>m <sup>3</sup> |
|----------------|--------------|--------------|-------------|----------------------------------|-------------------------------------|----------------|--------------------------|
| Z00W0981001001 | 6            | 10           | 60          | 20                               | 70                                  | 200            | 0,035                    |
| Z00W0981001002 | 8            | 12           | 80          | 20                               | 75                                  | 150            | 0,035                    |
| Z00W0981001003 | 10           | 14,5         | 110         | 20                               | 70                                  | 100            | 0,035                    |
| Z00W0981001006 | 13           | 19           | 185         | 20                               | 66                                  | 50             | 0,035                    |

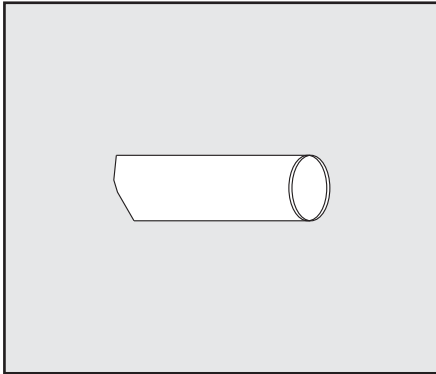
**TUBO TRASPARENTE RINFORZATO POLIESTERE**

| Cod.           | Ø Int.<br>mm | Ø Est.<br>mm | Peso<br>g/m | Press. Es.<br>kg/cm <sup>2</sup> | Press. Scopp.<br>kg/cm <sup>2</sup> | LG rotolo<br>m | Volume<br>m <sup>3</sup> |
|----------------|--------------|--------------|-------------|----------------------------------|-------------------------------------|----------------|--------------------------|
| Z00W0981001101 | 6            | 12           | 105         | 18                               | 54                                  | 100            | 0,026                    |
| Z00W0981001102 | 8            | 14           | 130         | 15                               | 45                                  | 100            | 0,038                    |
| Z00W0981001103 | 10           | 16           | 150         | 15                               | 45                                  | 100            | 0,047                    |
| Z00W0981001104 | 13           | 19           | 185         | 12                               | 36                                  | 100            | 0,058                    |
| Z00W0981001105 | 16           | 22           | 220         | 10                               | 30                                  | 50             | 0,042                    |
| Z00W0981001106 | 19           | 26           | 300         | 10                               | 30                                  | 50             | 0,080                    |
| Z00W0981001107 | 25           | 33           | 445         | 8                                | 24                                  | 50             | 0,110                    |

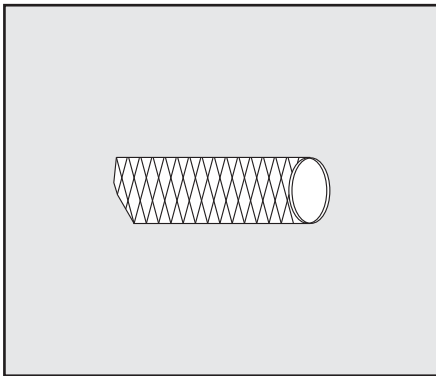

**TUBO PVC TRASPARENTE RINFORZO IN ACCIAIO**

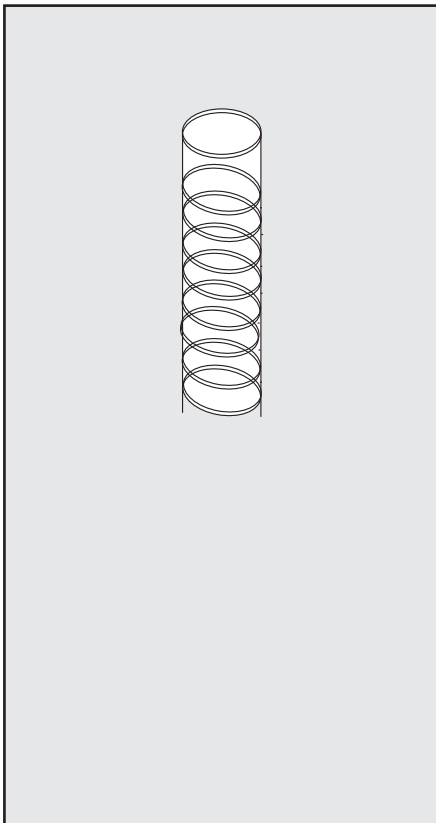
| Cod.           | Ø Int.<br>mm | Peso<br>g/m | Spess.<br>mm | Raggio<br>curvat. mm | Press. Eser.<br>kg/cm <sup>2</sup> | Press. Scoppio<br>kg/cm <sup>2</sup> | Depressione<br>m H <sub>2</sub> O | LG rotolo<br>m | Volume<br>m <sup>3</sup> |
|----------------|--------------|-------------|--------------|----------------------|------------------------------------|--------------------------------------|-----------------------------------|----------------|--------------------------|
| Z00W0981001201 | 6            | 130         | 3            | 13                   | 7                                  | 35                                   | 9,5                               | 60             | 0,022                    |
| Z00W0981001202 | 8            | 150         | 3,5          | 16                   | 7                                  | 35                                   | 9,5                               | 60             | 0,026                    |
| Z00W0981001203 | 10           | 160         | 3            | 18                   | 7                                  | 35                                   | 8,5                               | 60             | 0,026                    |
| Z00W0981001204 | 12           | 180         | 3            | 23                   | 6                                  | 30                                   | 8,5                               | 60             | 0,038                    |
| Z00W0981001205 | 14           | 205         | 3            | 26                   | 6                                  | 30                                   | 8,5                               | 60             | 0,039                    |
| Z00W0981001206 | 16           | 250         | 3,2          | 30                   | 6                                  | 30                                   | 8,5                               | 60             | 0,051                    |
| Z00W0981001207 | 18           | 300         | 3            | 32                   | 5                                  | 25                                   | 8,5                               | 60             | 0,073                    |
| Z00W0981001208 | 20           | 350         | 3            | 34                   | 5                                  | 25                                   | 8,5                               | 60             | 0,081                    |
| Z00W0981001209 | 22           | 380         | 3            | 38                   | 5                                  | 25                                   | 8,5                               | 60             | 0,089                    |
| Z00W0981001210 | 25           | 500         | 3,5          | 42                   | 5                                  | 25                                   | 8,5                               | 60             | 0,116                    |
| Z00W0981001211 | 30           | 600         | 4            | 50                   | 4                                  | 20                                   | 8,5                               | 60             | 0,161                    |
| Z00W0981001212 | 32           | 650         | 4,5          | 53                   | 4                                  | 20                                   | 8,5                               | 60             | 0,182                    |
| Z00W0981001213 | 35           | 700         | 4,5          | 58                   | 4                                  | 20                                   | 8,5                               | 60             | 0,195                    |
| Z00W0981001214 | 38           | 800         | 4,5          | 63                   | 4                                  | 20                                   | 8,5                               | 30             | 0,126                    |
| Z00W0981001215 | 40           | 870         | 5            | 66                   | 4                                  | 20                                   | 8,5                               | 30             | 0,166                    |
| Z00W0981001216 | 45           | 1100        | 5            | 74                   | 4                                  | 20                                   | 8                                 | 30             | 0,191                    |
| Z00W0981001217 | 50           | 1250        | 5            | 82                   | 4                                  | 20                                   | 8                                 | 30             | 0,218                    |
| Z00W0981001218 | 60           | 1700        | 6            | 130                  | 3,5                                | 18                                   | 8                                 | 30             | 0,269                    |
| Z00W0981001219 | 64           | 1800        | 5,5          | 138                  | 3,5                                | 18                                   | 8                                 | 30             | 0,323                    |
| Z00W0981001220 | 70           | 1950        | 6,5          | 151                  | 3,5                                | 18                                   | 7                                 | 30             | 0,389                    |
| Z00W0981001221 | 76           | 2200        | 7            | 164                  | 3,5                                | 18                                   | 7                                 | 30             | 0,492                    |
| Z00W0981001222 | 80           | 2350        | 6,5          | 172                  | 3,5                                | 18                                   | 7                                 | 20             | 0,387                    |
| Z00W0981001223 | 90           | 2900        | 7            | 192                  | 3                                  | 15                                   | 7                                 | 20             | 0,424                    |
| Z00W0981001224 | 102          | 3250        | 7            | 215                  | 2,5                                | 12                                   | 7                                 | 20             | 0,518                    |
| Z00W0981001225 | 105          | 3350        | 7,5          | 221                  | 2,5                                | 12                                   | 7                                 | 20             | 0,535                    |

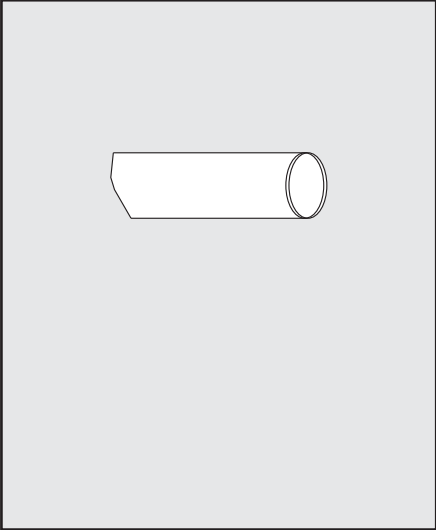

**TUBO GOMMA 20 BAR  
NERO TELATO**

Cod.                    Ø Int.            Ø Est.            Press. Es.            LG rotolo  
                                 mm                mm                kg/cm<sup>2</sup>            m



|                |    |    |    |     |
|----------------|----|----|----|-----|
| Z00W0981002001 | 6  | 14 | 18 | 100 |
| Z00W0981002002 | 8  | 17 | 18 | 100 |
| Z00W0981002003 | 10 | 19 | 18 | 100 |
| Z00W0981002004 | 13 | 23 | 18 | 100 |
| Z00W0981002005 | 16 | 26 | 18 | 100 |

**UGELLO MULTIPIO 1/4**

Cod.



Z00W0900400100            UGELLO MULTIPIO 1/4

**PISTOLA SOFFIAGGIO ALLUMINIO**

Cod.



Z00W0900400101            PISTOLA SOFFIAGGIO ALLUMINIO

**PISTOLA SOFFIAGGIO PLASTICA**

Cod.



Z00W0900400102

PISTOLA SOFFIAGGIO PLASTICA L MEDIA

**FASCETTE STRINGITUBO A VITE LARGHEZZA NASTRO MM 9  
PER TUBI DA DN 7 A DN 160**

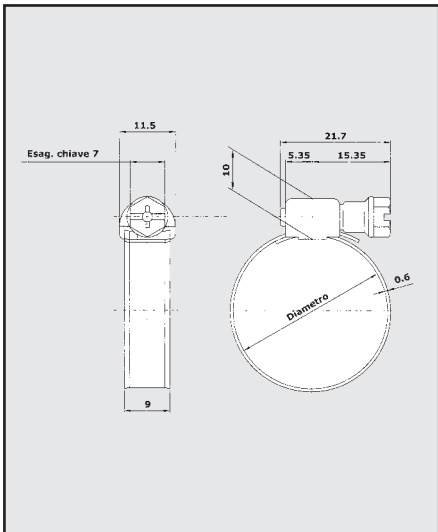

**FASCETTE STRINGITUBO A VITE LARGHEZZA NASTRO MM 12  
PER TUBI DA DN 15 A DN 400**

